



E10-mini

Instructions

E10-mini

SAFETY

Keep the manual accessible

These instructions form an integral part of the furniture lock.

- Keep these instructions with the furniture lock.
- Ensure that the instructions are available for the assembly fitter / operator.
- Please include these instructions if you sell the furniture lock or pass it on.

Important safety information

The furniture lock is built in accordance with recognised safety regulations. When working with and on the furniture lock, however,

there are residual risks that can cause danger to life and limb remain. The following safety notices must therefore be observed and followed.

Safety

Avoid risk of explosion

The furniture lock is not suitable for use in areas where there is a risk of explosion. Assembling and operating the furniture lock in an area where there is a risk of explosion can lead to serious injury or death.

- Only assemble and operate the locks in areas where there is no explosive atmosphere.

Choking risk

Children can become injured after swallowing small parts.

- Make sure that small parts e.g. locking media or screws are kept out of the reach of children.

Avoid property damage and malfunction

Property damage can occur as a result of incorrect storage for an extended period of time.

- Store the furniture lock and its components in the original packaging in a dry and dust-free place.

Property damage can occur

as a result of the furniture lock being assembled and operated incorrectly.

- Read these instructions carefully before assembling the furniture lock and putting it into operation.
- Follow the instructions step by step.
- Never touch the furniture lock's electronic components.
- Protect the parts of the furniture lock against moisture.
- Handle the furniture lock carefully to prevent scratches.
- Secure the screws using the specified torque.

Risk of property damage as a result of incorrect cleaning and maintenance.

- Do not lubricate any parts of the furniture lock.
- Clean the housings and closing devices with a soft, damp cloth; do not use any cleaning agents.

Appropriate user training

- People working on and with the furniture lock must have basic manual skills so that they can safely make screw connections and drill holes if necessary.
- Installers of the furniture lock must understand how it works and how the individual components interact.

E10-mini

INSTRUCTIONS



We highly recommend changing master code and user codes upon receipt of the products.

Default Settings

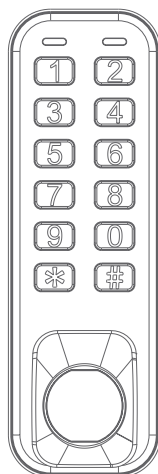

MASTER CODE:

2 0 0 5 0 3 3 0

(8 digit code)

PRIVATE MODE:

1 1 1 1

(4 digit code)

FACTORY MODE:

Public Mode

Private Mode / Public Mode

INSTRUCTIONS

Set Private Mode / Single user Mode

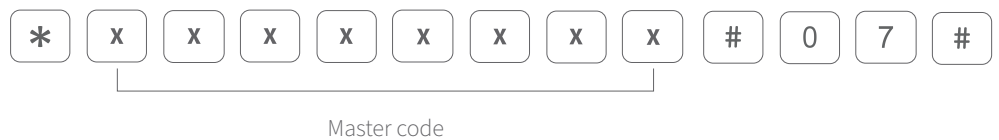
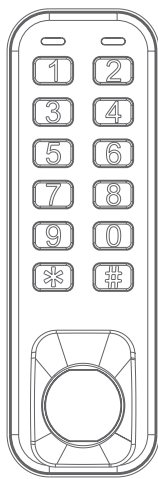

User code reset to 1111.

The lock will now be closed when the knob is turned in closed position.

Set Public Mode / Multi user Mode

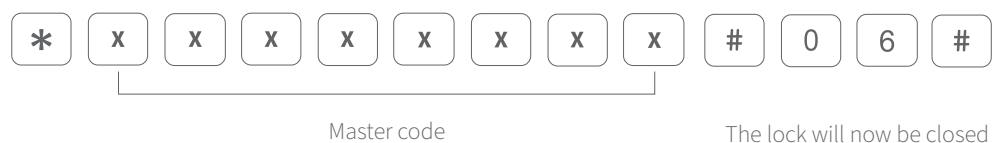
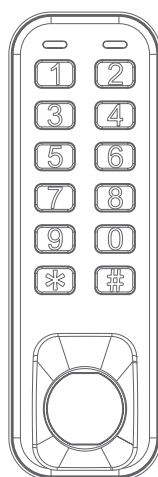

The lock will now be closed when a 4 digit code will be set and knob turned in closed position.

REMINDER: Default master code: 20050330 (8 digit code)

How to open the lock?

INSTRUCTIONS

Open/Close in Private Mode / Single user Mode

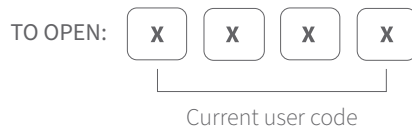
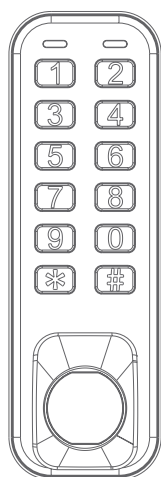

The knob is blocked automatically when turned in closed position.

REMINDER: Default user code: 1111 (4 digit code)

Open/close in Public Mode / Multi user Mode

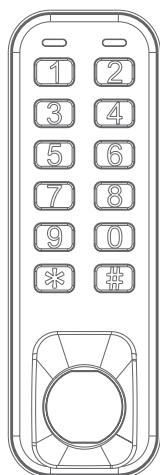

The knob is blocked automatically when turned in closed position.



The lock can now be used by another user.

Master Code functions

INSTRUCTIONS

Open using Master Code

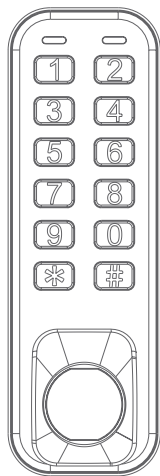

Master code

Private Mode : Knob can be turned in open position, the knob will lock again in closed position.

Public Mode : Knob can be turned, current user code is erased.

Programming Master Code

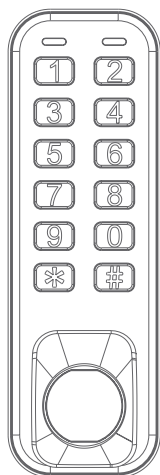

Current master code



New master code



New master code

REMINDER: Default master code: 20050330 (8 digit code)

Master Code functions

INSTRUCTIONS

Set or change the User Code (Private Mode)

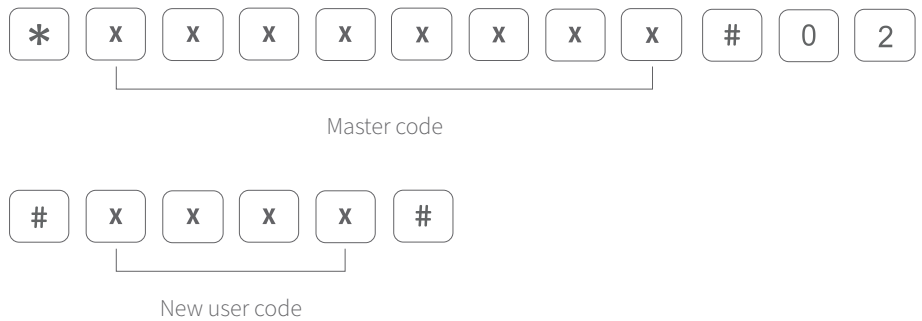
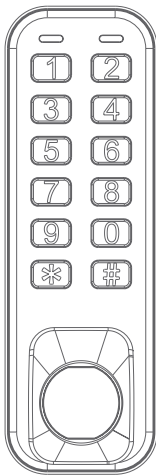

Delete User Code (Private Mode)

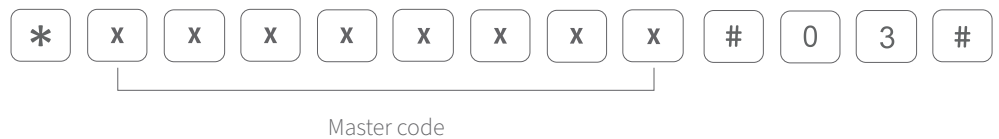
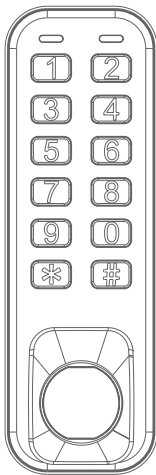

REMINDER: Default user code: 1111 (4 digit code)

REMINDER: Default master code: 20050330 (8 digit code)

Sub-Master Code (Private Mode)

INSTRUCTIONS

Set or change the Sub-Master Code

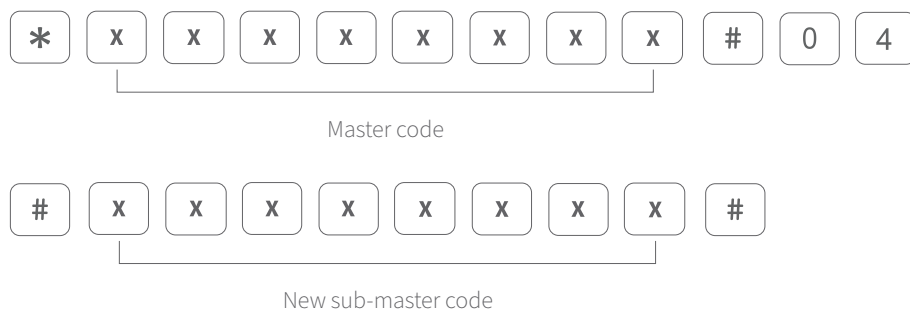
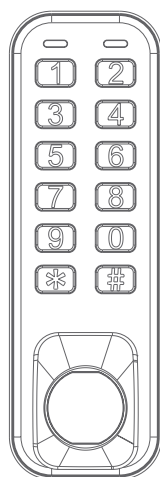

REMINDER: Default master code: 20050330 (8 digit code)

Delete Sub-Master Code

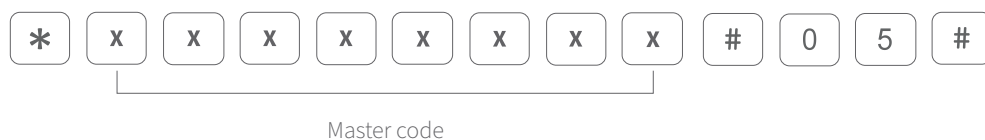
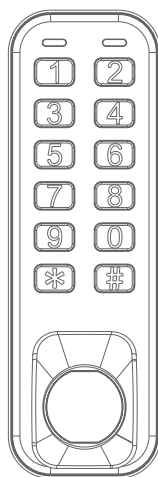

Sub-Master Code functions

INSTRUCTIONS

Open



ENTER SUB-MASTER CODE:



Sub-master code

Change the Sub-Master Code



Current sub-master code



New sub-master code

Change the User Code (only in Private Mode)



Current sub-master code



New user code

Technician Code Functions

INSTRUCTIONS

Set or change the Technician Code (Public Mode)

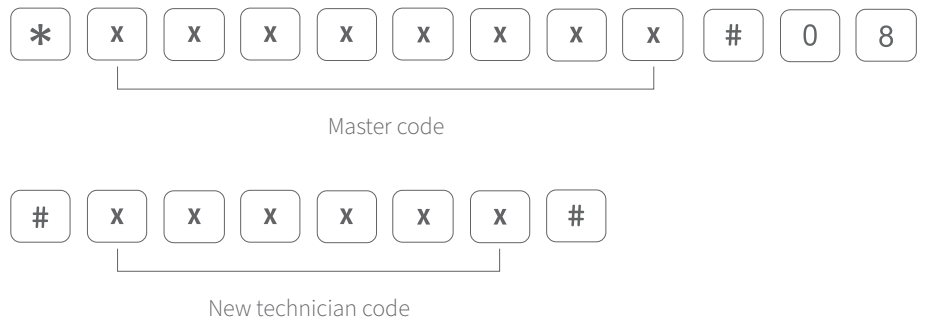
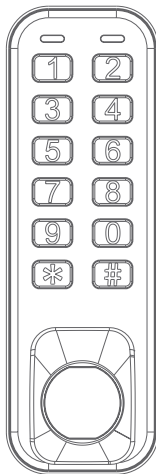

Note: the technician code must be 6 digit code
The technician code doesn't remove the user code.

Delete the Technician Code (Public Mode)

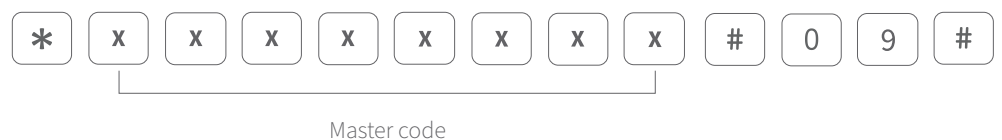
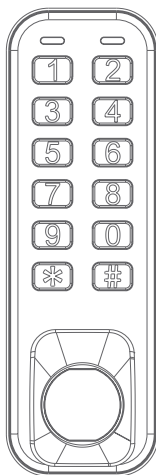

REMINDER: Default master code: 20050330 (8 digit code)

Auto-unlock function

INSTRUCTIONS

Activate/Deactivate the Auto-unlock Function (Public Mode)

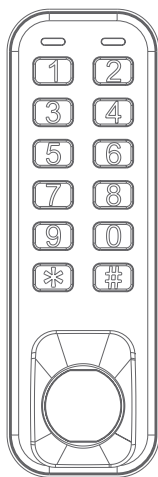

ACTIVATE:

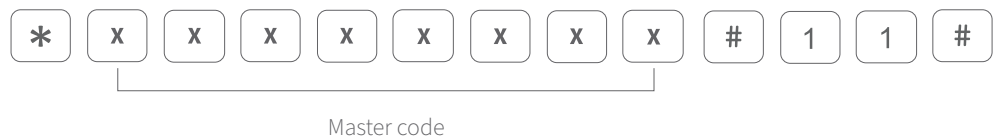

DEACTIVATE:

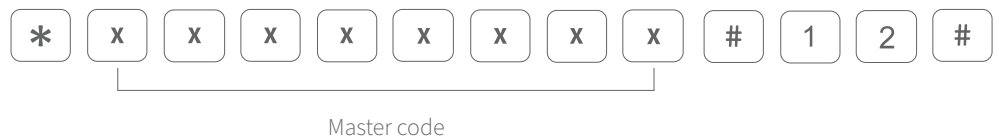

Set Auto-unlock time (Public Mode)

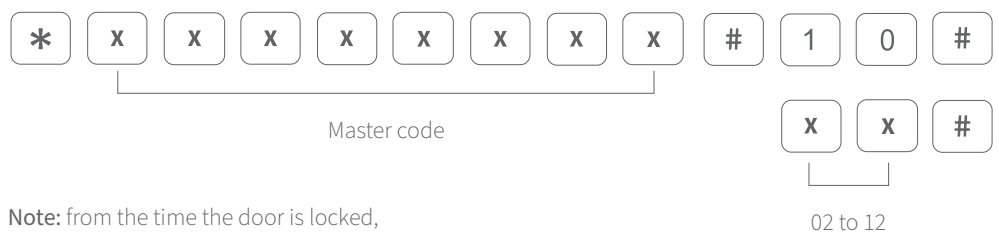
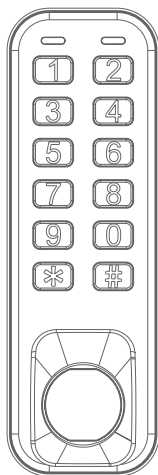

Note: from the time the door is locked, the lock begins to count and unlock xx hours later and the “xx” is 02, 04, 06, 08, 10 or 12 (even numbers).

REMINDER: Default master code: 20050330 (8 digit code)

Master key and reset

INSTRUCTIONS

Master key

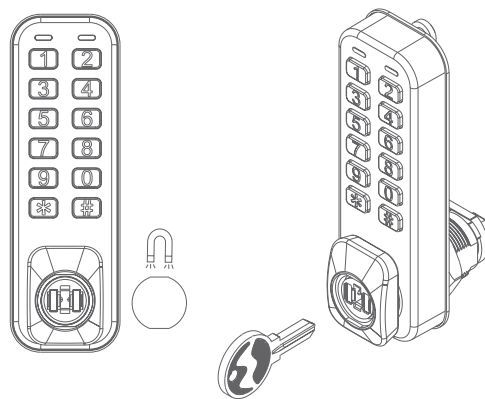

1. Remove the cover plate with a magnet.
2. Use the Master key (right image)
3. The existing user code will be retained by the lock when using the Master key override.

Reset the lock to default settings

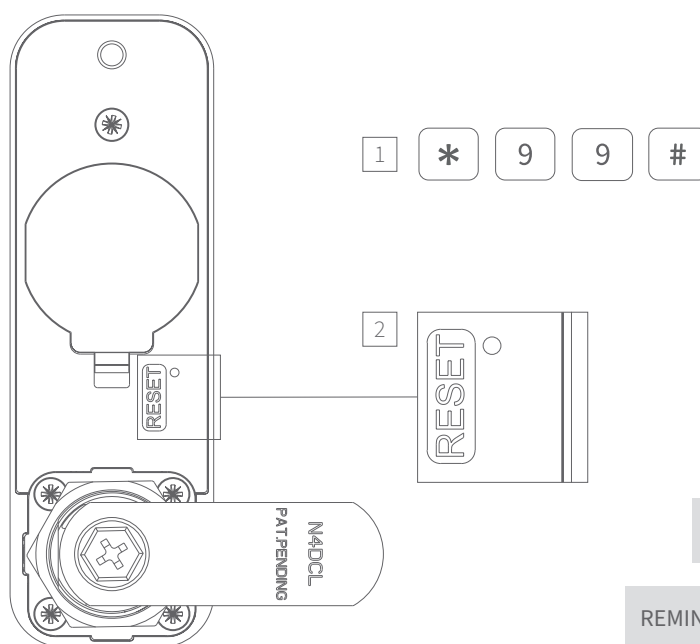

1. Press the reset button using a clip/pin in the RESET hole at the back.
2. Enter the reset sequence. Master code and user code are reset to default, the lock will be reset to factory mode.

REMINDER: Default user code: 1111 (4 digit code)

REMINDER: Default master code: 20050330 (8 digit code)

Battery warning

INSTRUCTIONS



Alarm will sound if the battery power is low (5 beeps, red light flashes 3 times before blue light flashes once) informing users to replace the batteries.

1. Remove the lock from the furniture.
2. Remove the gasket to access the battery case.
3. Remove the battery cover.

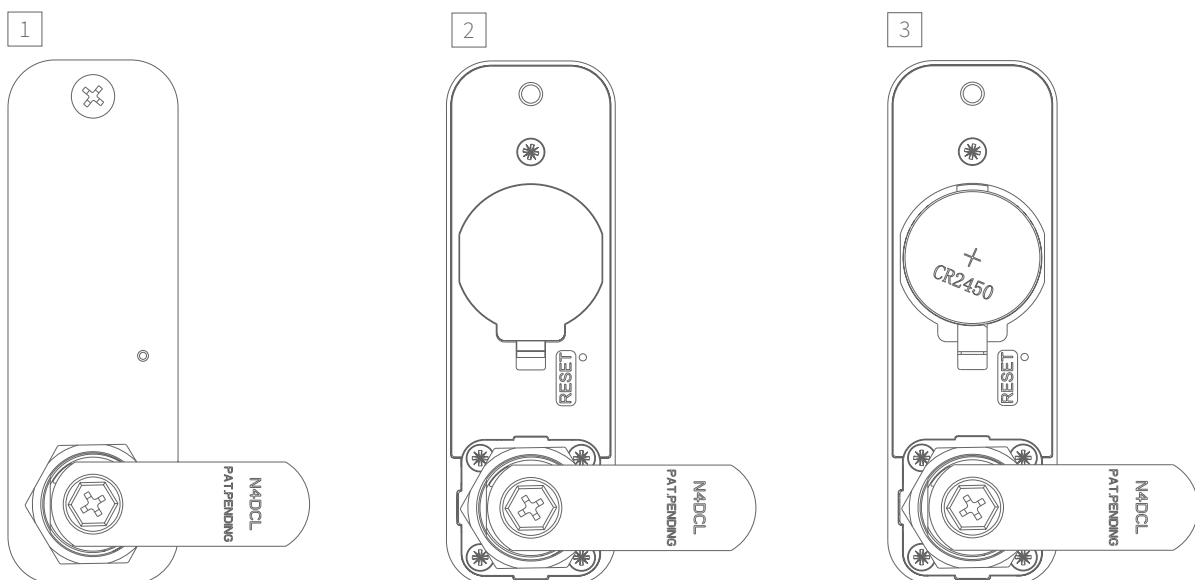

PARAMETER	NOMINAL VOLTAGE	DIMENSION	SINGLE WEIGHT	NOMINAL CAPACITY	STANDARD DISCHARGE CURRENT	WORKING TEMPERATURE	STORAGE CONDITION
CR2450	3V	24.5 * 5 mm max	6.6 g max	600mAh	0.4mA	-20°C / +70°C	20°C ± 2°C, 60% ± 15%RH



**WE BELIEVE EVERYONE AND
EVERYTHING OF VALUE
DESERVES TO BE KEPT SECURE,
WITHOUT COMPROMISE.**

That is why you can count on us to help you create the perfect security

for your home. Together with your trusted security experts we will do whatever it takes to make your home the safest place it can be.

Now and in the future.

www.dom-security.com.

DOM UK LTD

Unit 12
Cleton Street Business Park
Cleton Street, Tipton DY4 7TR
United Kingdom

T +44 (0)121 - 569 7790

E sales@dom-uk.co.uk

Your expert security advisor:

DOM RONIS

Rue de Neuilly
18600 Sancoins
France

T +33 (0) 2 48 74 96 50

E contact@dom-ronis.fr

WWW.DOM-SECURITY.COM