











PRODUCT RANGE

	Model	Type	Applications
	EXHAUST SWING ARM	Suction arm	Extract gases, fumes and all kind of pollutants direct from source
	COBRA®	Centrifugal fan	Ventilation of pits, tanks, vessels, cellars, premises, process, etc.
	EXTRACTAIR® C	Centrifugal fan	Connected to a piping network: Extraction of polluted air on workstation
			Installed on roof: ventilation and extraction
	UNILINE®	Centrifugal fan	To convey clean air or Air with fine dust.
	CENTRIPLAST®	Thermoplastic centrifugal fan	Corrosive gases, wet or polluted air
	RADIAL®	Centrifugal fan	Extraction of dust air and small waste
	NYLAIR®	Helicoidal fan	For improving working or production conditions: Air cleaning and renewal Cooling too hot environment Acceleration of drying and evaporation Extraction of vapours and steam Ventilation of confined areas
	PROJECTAIR®	Helicoidal fan	
	EXTRACTAIR®	Helicoidal fan	
	DOWNDRAUGHT TABLE	Ventilated workstation High efficiency	All types of dust and fumes: plastic, aluminum, carbon, composite glass, chrome VI, etc.

B.O.A. EXHAUST SWING ARM

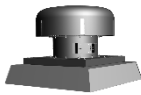
APPLICATIONS

- + Extract gases, fumes and all kind of pollutants direct from source.
- + Easy to use. Adjusted to different positions to reach max efficiency.

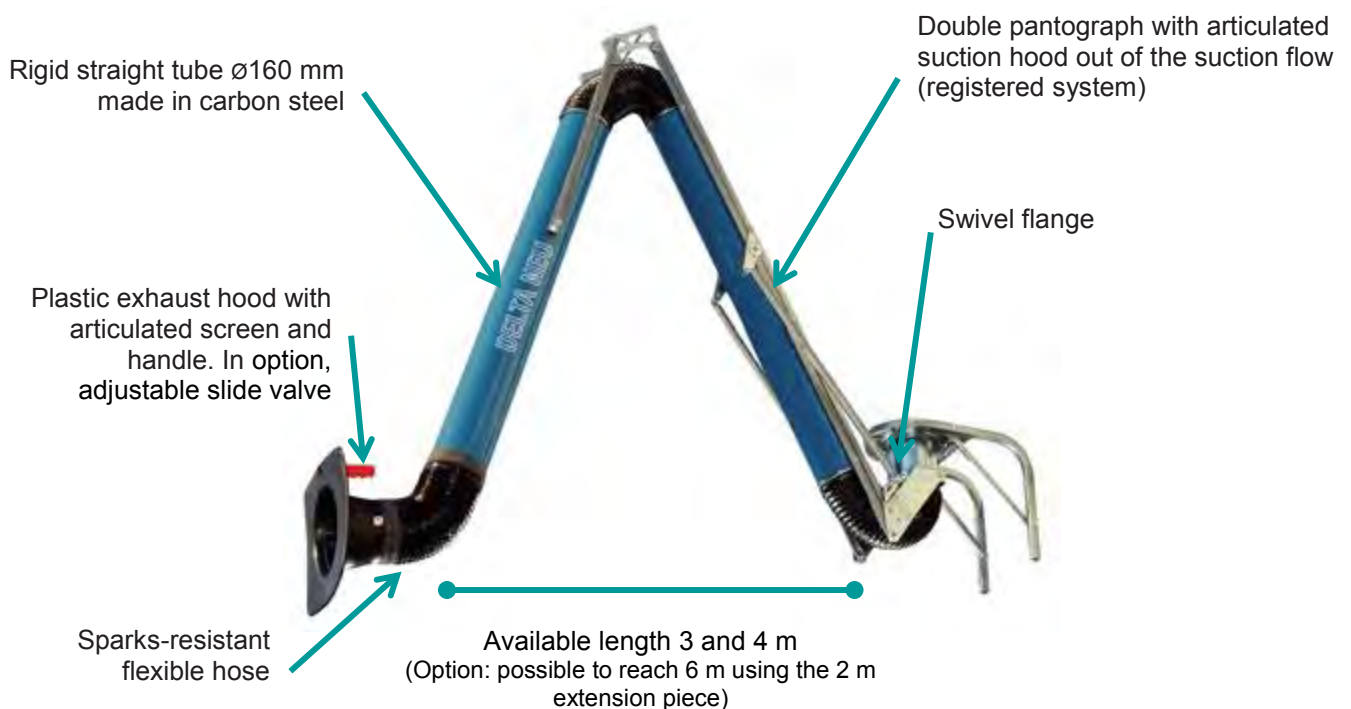

ADVANTAGES

- + **Polyvalent** : Used to solve all kind of air pollution exhaust direct from source
- + **Max efficiency** : due to right design of suction hood
- + **Handling** : Easy to handle and will stay in desired position thanks to the used of pantograph perfectly balanced by springs.
- + **Easy to maintain**: all articulations are visible and accessible from outside
- + **Strong material**: Reinforced by steel tubing and pantograph
- + **Safety**: Design taking into account protection of the operators and environment.



ATEX Version: This version is ATEX classified 94/9/CE group II Class 2 area 1 (gas) and avoid all electrostatic problems and make those units ATEX conform to area classified 2. Offer max security for the operatives in industrial area when hazardous from gas or dust is involved.

DIMENSIONS

Standard version DN 160

Length	A max	B max
3 m	2 989	859
4 m	3 989	1 349

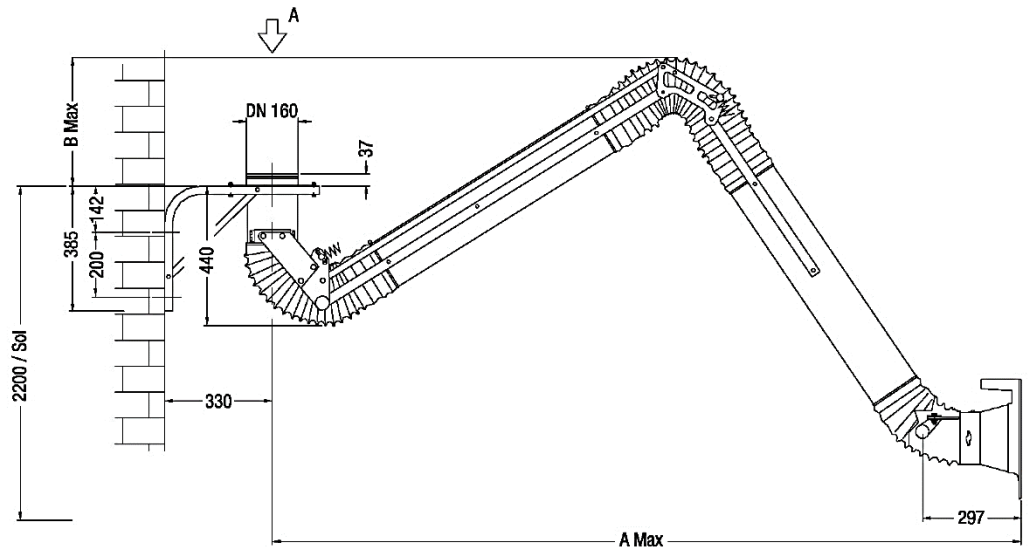

ATEX Version DN 160

Length	A max	B max
3 m	3 375	315
4 m	4 375	415

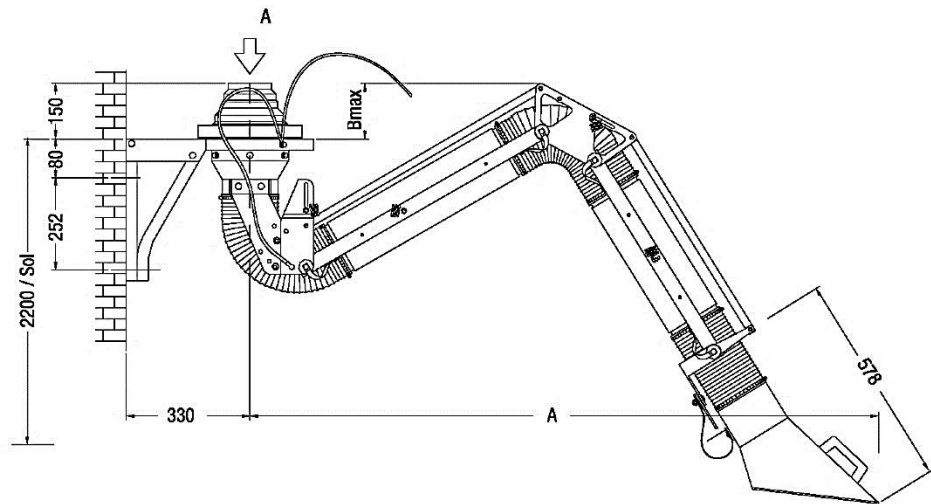

FAN TECHNICAL CHARACTERISTICS

Model	Flowrate	Pressure	Speed	Power	Voltage	Frequency	Protection
STANDARD	1200 m ³ /h	170 daPa	2 850 tr/min.	0,75 kW	3 x 230 x 400 V	50 Hz	IP 55
ATEX	1200 m ³ /h	170 daPa	2 850 tr/min.	0,75 kW	3 x 230 x 400 V	50 Hz	IP 65 Eexd2GD



COBRA® SUPERCOBRA® HYPERCOBRA® CENTRIFUGAL FANS

Cobra® is a centrifugal fan designed to the most ventilation configurations: pits, tanks, vessels, cellars, premises, process...

They are made entirely of ALUMINUM
CAST IRON



OPERATION

- Range of airflows: 500 to 1 700 m³/h.
- Specific models for installation in ATEX zone 2/22 (category II3GD and II2GD).
- In conformity with standard ErP 2009/125 / EC applicable to fans.
- Wide range of accessories: expandable sleeves, heater, filters, grids ...
- Available with three-phase asynchronous motor, single-phase, compressed air, 24 VDC.

CONNECTION

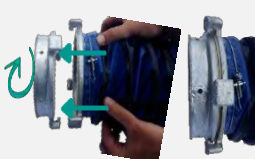
NEU Type		Pads assembling and locking with handles
ROTATING CONNECTION (ZAG)		Face-to-face positioning and locking by rotation

ADVANTAGES

- Its compact design makes it adaptable to the most various operations of service: purification, maintenance, fresh air input and elimination of contaminated air.
- Its robustness makes it an ideal equipment in the most difficult site conditions: construction phases, intervention ... or for its installation in a manufacturing process: solvent shaft ventilation, exhaust gas extraction, hydrocarbon vapor capture, H₂S extraction in sewers, wells
- Suitable in a corrosive environment.
- ATEX version available.



CHARACTERISTICS

Model	Motor				Weight			Sound level db(A)	
	Rotation speed (tr/mn)	Power kW	Pressure bars	Compressed air consumption l/min.	Mono 220 V	Three-phase 230 x 400 V	Compressed air	Electric Motor	Compressed air motor
COBRA®	2 825	0,18	/	/	19	19	/	62	/
SUPER COBRA®	2 800	0,75	4	1 740	30	28	26	60	84
HYPER COBRA®	2 800	0,75	5	2100	44	43	35	60	84

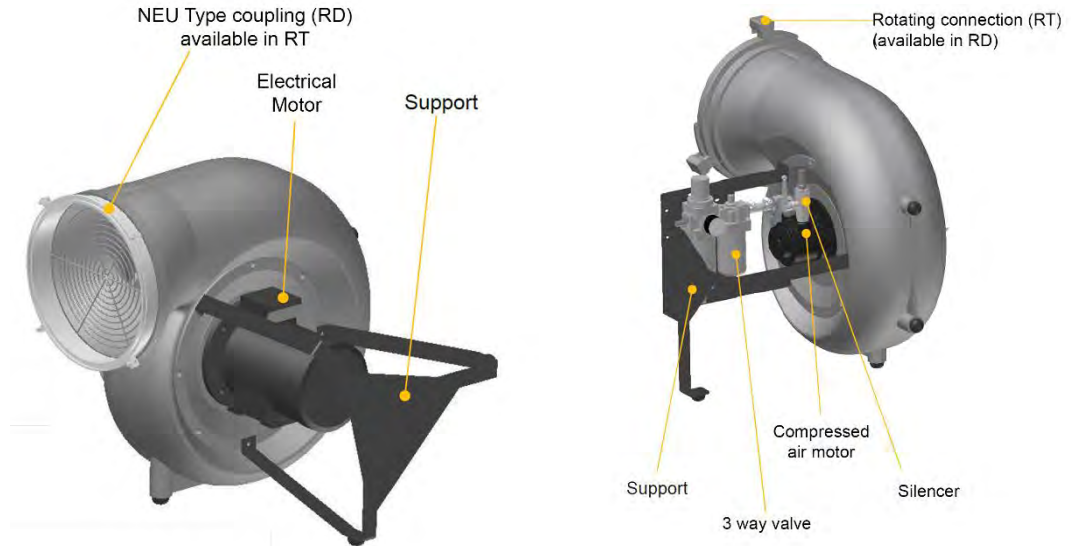





AIR FLOW

Model	Electrical motor + 10 m sleeve	Electrical motor + 20 m sleeve	C/A Motor + 10 m	C/A Motor + 20 m
COBRA®	600 m³/h	400 m³/h	---	---
SUPERCOBRA®	800 m³/h	660 m³/h	500-800 m³/h*	300-500 m³/h*
HYPERCOBRA®	2 500 m³/h	2 300 m³/h	1200-2500 m³/h*	800-1500 m³/h*

*Depending on the availability of pressure and compressed air flow

- ❖ The sound levels: measured in free field, 3m from the suction or the unconnected discharge
- ❖ Motor 3000 tr/min - 3x 230 x400 V or single-phase 230 V / 50 Hz
- ❖ Compressed air motors are designed for a pressure of 2 to 5 bar during operations. They require line lubrication prior to a dehydrating filter.

ACCESSORIES

	Sleeve		Heater		Extraction Hood
	Filter		2 directions branch		

EXTRACTAIR® C

GENERAL CENTRIFUGAL FANS

APPLICATIONS

NEU-JKF's range of centrifugal fans EXTRACTAIR® C are suited to various applications.

1. Connected to a piping network they allow the polluted air extraction on workstations such as:
 - Suction of welding fumes on an automatic welding line
 - Extraction of steam on preparation tanks
 - Extraction of ATEX steam on a paint preparation station
 - ...
2. Installed on the roof and connected to piping systems they allow:
 - Ventilate a building containing solvent products
 - Extracting steam from a washing room
 - ...

An adaptation plate allows connection of the turret to a laminated polyester or galvanised steel overlay. Possibility to install in the coaming an automatic closing flap.

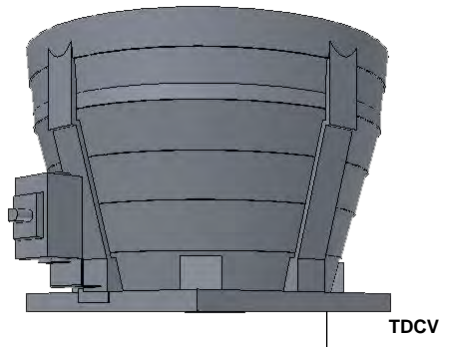
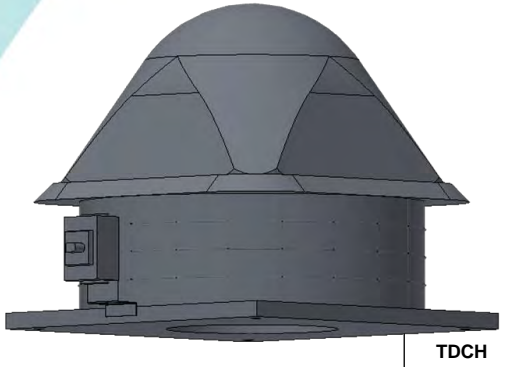

RANGE

3 versions:

Standard Extractair® TCDH
Horizontal air outlet
Rain proof protection in polyethylene

Standard Extractair® TCDV
Vertical air outlet
Vertical air outlet kit in polyethylene

TCDH ATEX Extractair® – Zone 1&2
Horizontal air outlet
Protection grid
Eexd II B T4 Motor



DIMENSIONS

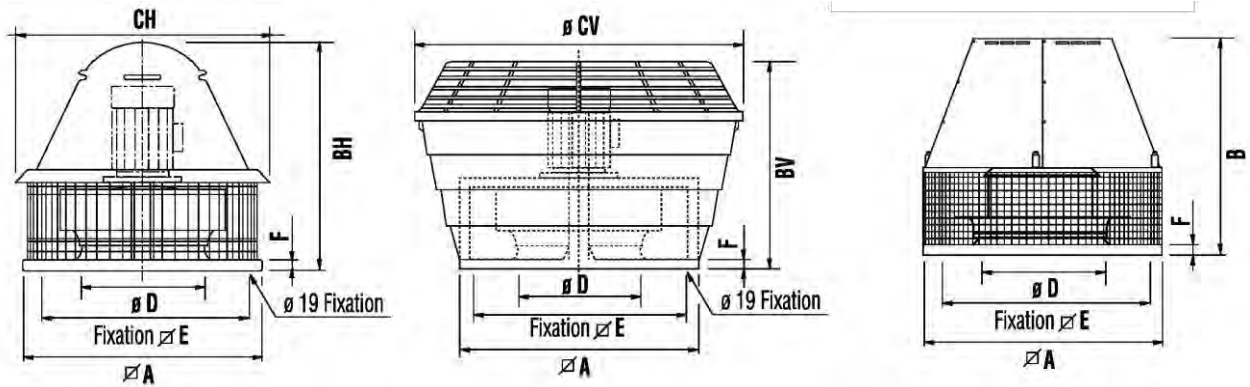

N°	Standard Version									ATEX Version					
	A	BV	CV	BH	CH	D	E	F	kg	A	B	D	E	F	kg
010	430	430	578	415	470	181	344	30	15	430	405	181	344	30	22
020	430	430	578	435	470	217	344	30	18	430	430	217	344	30	25
030	540	510	720	525	596	256	450	30	25	540	539	256	450	30	32
040	540	510	720	465	596	294	450	30	28	540	562	294	450	30	35
060	660	580	875	615	661	326	570	30	50	660	650	326	570	30	57
080	660	580	875	635	661	362	570	30	60	660	662	362	570	30	68
105	800	680	1060	760	849	399	668	30	75	800	726	399	668	30	90
195	946	790	1239	938	1037	537	830	30	100	946	900	537	830	30	126
250	1030	1005	1375	975	1037	581	830	40	120	1030	940	581	830	40	150

Model	Rpm	kW (standard)
010	3,000	0.55
020	1,500	0.25
	1,500	0.37
030	1,500 / 750	0.50
	1,500	0.55
040	1,500 / 750	0.50
	1,500	0.75
060	1,500 / 750	0.75
	1,000	0.25
	1,000 / 750	0.45
080	1,500	1.50
	1,500 / 750	1.70

Model	Rpm	kW (standard)
080	1,000	0.37
	1,000 / 750	0.45
	1,500	2.20
105	1,500 / 1,000	3.00
	1,500 / 750	2.80
	1,000	0.75
195	1,000 / 750	0.90
	1,000	3.00
	1,000 / 750	4.00
250	1000 / 500	4.00
	750	1.50
	1,000	5.50
	750	3.00

UNILINE[®], CENTRIPLAST[®], RADIAL[®] SE, GENERAL CENTRIFUGAL FANS

APPLICATIONS

NEU's range of centrifugal fans offer a wide selection to suit various applications:

1. Evacuation of polluted air to the workplace
2. Dust extraction
3. Cleaning of industrial premises (extraction of fumes, vapors, etc.)
4. General ventilation
5. Dust and small waste transfer

Available in ATEX version



UNILINE

Centrifugal fan made of steel, designed to convey clean air or air with fine dust.

CENTRIPLAST

Thermoplastic centrifugal fan designed for corrosive gases, wet or polluted air

RADIAL SE

High pressure steel centrifugal fan designed for the extraction of dust air and small waste

CHARACTERISTICS

	UNILINE 35-42-46	RADIAL SE	CENTRIPLAST®
Air characteristics	clean air	dusty air small waste	Corrosive gas, wet or polluted air
Configuration	Direct drive	Direct drive	Direct drive
Flow rate in m³/h	200 to 9000	300 to 1 500	200 to 10 000
Pressure in daPa	up to 400	up to 700	up to 280
Temperature	< 80°C	< 80°C	< 80°C
Models	N° 35 - 0,3 N° 35 - 0,42 N° 35 - 0,6 N° 42 - 0,5 N° 42 - 0,6N N° 42 - 0,6L N° 46 - 0,6L	N° 42 - 0,25 N° 50 - 0,25 N° 60 - 0,18	N° 25 N° 31 N° 40 N° 50 N° 56



Extraction of steam



Extraction of corrosive gases



Transfer of champagne cork capsules (mullet plates)



Extraction of welding fumes

Nylair[®] Extractair[®] Projectair[®] HELICOIDE FANS

In any situation in which air circulation improves working or production conditions, the **Nylair[®]** provides a suitable solution for:

- + air cleaning and renewal
- + cooling too hot environment
- + acceleration of drying and evaporation
- + extraction of vapours and steam
- + ventilation of confined areas

The **Nylair[®]** fans are helicoid fans covering a wide range of flowrate (1 000 to 44 000 m³/h).

They are in conformity to CE standards.

Their design allows a direct and easy installation in ducts.

Their robust construction is ideal in the most difficult conditions:

- + anti-corrosion protection
- + steel or thermoplastic and stainless-steel impellers

High temperature models for
corrosive area upon request



Available in ATEX version

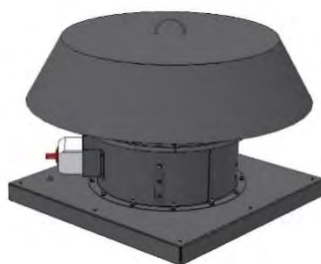

NEU JKF - 11000 rue de la Vallée - 59120 Valenciennes - France

CHARACTERISTICS

- + Wide range of airflow: **1 000 to 44 000 m³/h**.
- + Proximity switch (option).
- + Specific models for an installation in **ATEX 2/22** zone (category II3GD).
- + Conforms to the regulation **ErP 2009/125/CE** applicable to fans.
- + Wide range of accessories:
 - o **Nylair[®]**: protection grille, automatic louvers, cradles, air inlet bellmouth, fan support plate.
 - o **Extractair[®]**: automatic louvers, protection grille and roof sheet.
- + Design for duct installation.
- + Finishing: EPOXY RAL 7016 paint.
- + Three-phase synchronous motor 3 x 230 x 400 V – 50Hz insulation class F, IP55

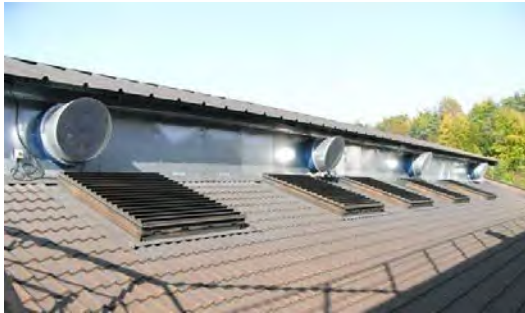

NYLAIR[®] RANGE

Model	Casing inside diameter	Operating speed	Motor power	Weight	Noise level	Air flow* maxi
Standard & ATEX	mm	tr/min	kW	kg	dB(A)	m ³ /h
NYLAIR [®] 31	Ø 315	960	0,09	13	46	1440
		1440	0,18		56	2170
NYLAIR [®] 35	Ø 355	960	0,09	13	48	2130
		1440	0,18		58	3340
		2880	0,37	64	4430	
NYLAIR [®] 40	Ø 400	960	0,09	15	52	2430
		1440	0,37	17	57	4290
		2880	1,5	24	76	7350
NYLAIR [®] 50	Ø 500	960	0,18	19	49	5890
		1440	0,37		58	7200
		2880	2,2	29	78	16090
NYLAIR [®] 56	Ø 560	960	0,75	31	70	8870
		1440	1,5	33	80	14100
NYLAIR [®] 63	Ø 630	960	0,75	35	56	10800
		1440	1,5	37	66	17000
NYLAIR [®] 71	Ø 710	960	0,75	41	63	16300
		1440	2,2	49	71	21900
NYLAIR [®] 80	Ø 800	720	0,75	64	58	15600
		960	1,5		64	21100
		1440	4	74	74	33600
NYLAIR [®] 90	Ø 900	720	1,1	79	58	19800
		960	3	84	66	28300
NYLAIR [®] 100	Ø 1 000	720	2,2	107	65	32600
		960	4	107	72	43600

*Approx.fan not connected



EXTRACTAIR® RANGE

Model	Casing inside diameter	Operating speed	Motor power	Weight	Noise level	Air flow* maxi
Standard & ATEX	mm	tr/min	kW	kg	dB(A)	m³/h
EXTRACTAIR® 50	Ø 500	960	0,18	55	62	5 600
		1440	0,37	55	71	7 000
		2880	2,2	65	91	15 500
EXTRACTAIR® 56	Ø 560	960	0,75	72	83	8 600
		1 440	1,5	74	93	13 200
EXTRACTAIR® 63	Ø 630	960	0,75	91	69	10 100
		1440	1,5	93	79	16 000
EXTRACTAIR® 71	Ø 710	960	0,75	109	76	14 300
		1 440	2,2	117	84	20 800
EXTRACTAIR® 80	Ø 800	720	0,75	146	71	14 400
		960	1,5	146	77	18 900
		1440	4	156	87	30 000
EXTRACTAIR® 90	Ø 900	720	1,1	169	71	19 000
		960	3	174	79	26 000
EXTRACTAIR® 100	Ø 1 000	720	2,2	217	78	24 500
		960	4	217	85	34 300

*Approx.fan not connected







PROJECTAIR® RANGE

Model	Casing inside diameter	Operating speed	Motor power	Weight	Air flow* maxi
Standard	mm	tr/min	kW	kg	m³/h
PROJECTAIR® 50	Ø 500	960	0,18	23	5890
		1440	0,37		7200

*Approx.

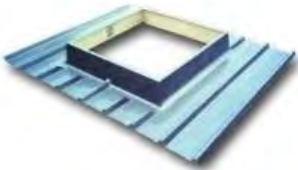
ACCESSORIES

	Air inlet bellmouth	Can be installed at air inlet for noisereduction while increasing the airflow
	Protection grille	Protect operators and avoid bird entry
	Automatic louver	Prevent back draught
	Roof sheet	EXTRACTAIR® can be installed horizontally on any type of roof
	Fan support plate	Steel sheet metal plate to enable fixing on wall...
	Cradle	NYLAIR® can be installed on any type of structure

VENTILATED WORKSTATION DOWNDRAUGHT TABLE



- + Ensure a clean and protected working environment
- + Operatives safety
- + In conformity with applicable regulations
- + Facilitates air recirculation within the workspace in the case of non-CMR dusts (*)
- + Energy savings
- + Three levels of filtration for optimum results

SUITABLE DUST TYPES

- plastic
- aluminium
- carbon
- composite
- glass
- and more

EXAMPLE OF APPLICATIONS

- + Precision-grinding and fitting parts
- + Cleaning small parts
- + Manual sanding
- + Dust control at finishing work
- + Dust control at small weighing work
- + Dust control at mixing stations
- + Retouching paintwork
- + Extracting pollutants (polish, varnish, etc.)
- + and more



EN 779 STANDARD

Average efficiency of synthetic dust		WIRE MESH FILTER	Average efficiency with 0.4 µm particles		PLEATED MEDIA FILTER
	Large particles		M5 < 60 % (*)	Medium-sized particles	
G1 < 65 %			M6 < 80 %		
G2 < 80 %			F7 < 90 %		
G3 < 90 % (*)			F8 < 95 %		
G4 < 90 %			F9 < 95 %		

EN 1822 STANDARD

Purification efficiency	MINI PLEAT FILTER (*)	Purification efficiency	MINI PLEAT FILTER (*)
E10 > 85 %		H14 > 99,995 %	
E11 > 95 % (*)		U15 > 99,9995 %	
E12 > 99,5 %		U16 > 99,99995 %	
H13 > 99,95 %		U17 > 99,999995 %	

(*) : Provided all the pollutants released are known

SAFETY

- + Suction speeds comply with the recommendations of INRS (French office for health and safety)
- + Level of filter contamination monitored by 2 pressure gauges
- + Easy to maintain

DESCRIPTION

1	Fans
2	E11 finishing filters (or activated carbon filters - optional)
3	Power socket
4	Adjustable lighting strip
5	Articulated side panels
6	Non-scratching work surface
7	Pressure gauges
8	Electrical control cabinet
9	Particle recovery units
10	G3 + M5 pre-filters

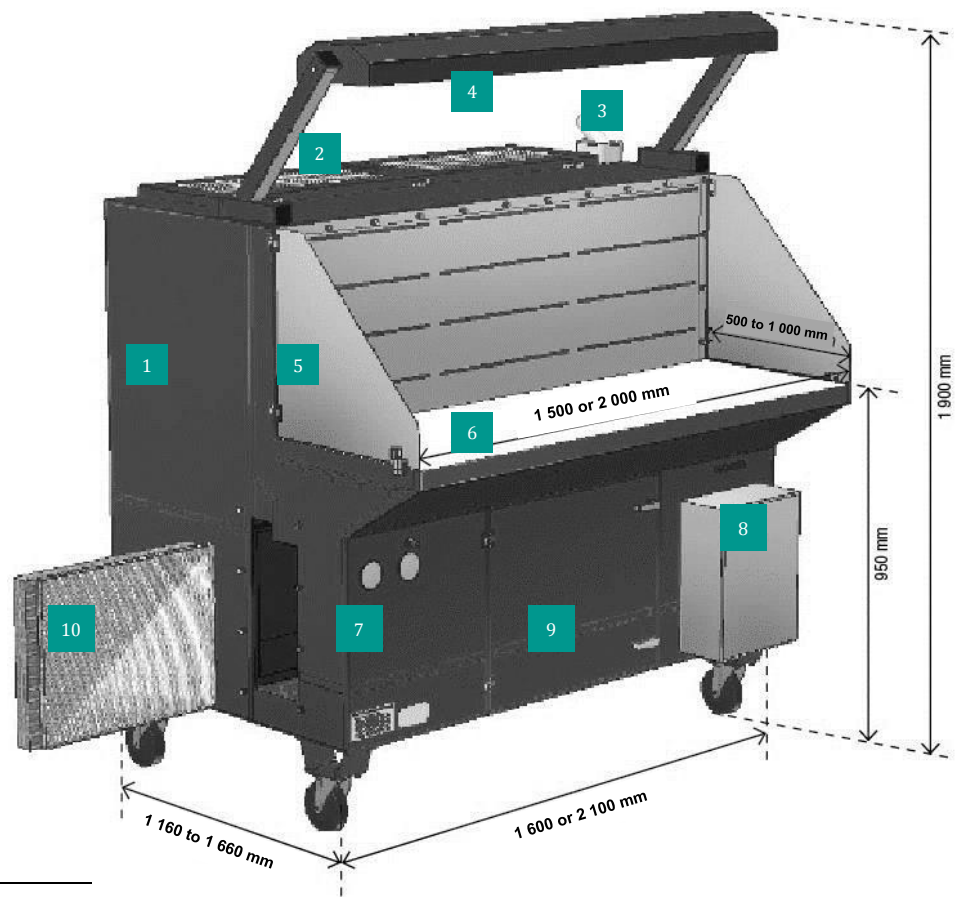

CHARACTERISTICS

- + Treated air circulation:
2 700 m³/h to 6 300 m³/h
- + 2 x 1.27 kW fans
- + Fully mobile (swivel castors)
- + 2 x pressure gauges
- + Lateral access covers to the G3/M5 filters
- + Noise level at 1 m: 68 dB(A) ± 2 dB (in accordance with EN ISO 3746)
- + Plug and play: requires a simple single-phase power supply (230 V – 16 A)

RANGE

MODEL	OVERALL DIMENSIONS (mm)			WEIGHT (kg)
	Length	Width	Height	
1 500 x 500	1 160	1 600	1 900	340
1 500 x 600	1 260	1 600	1 900	350
1 500 x 700	1 360	1 600	1 900	360
1 500 x 800	1 460	1 600	1 900	370
1 500 x 900	1 560	1 600	1 900	380
1 500 x 1 000	1 660	1 600	1 900	390
2 000 x 500	1 160	2 100	1 900	410
2 000 x 600	1 260	2 100	1 900	420
2 000 x 700	1 360	2 100	1 900	430
2 000 x 800	1 460	2 100	1 900	440
2 000 x 900	1 560	2 100	1 900	450
2 000 x 1 000	1 660	2 100	1 900	460

OPTIONS

- + Vice holders
- + 2 x pressure sensors with warning lights to indicate when the filters are contaminated
- + Activated carbon finishing filters
- + Translucent side panels

The manufacturer expressly reserves the right to make any changes to these models that it deems necessary.